

TNC8105WP-0179

TNC Jack Crimp For Bulkhead

75Ω

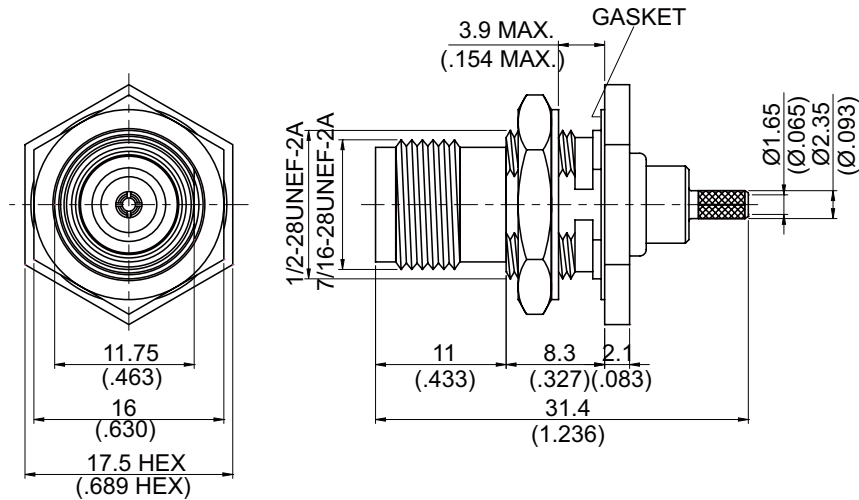

MOUNTING HOLE

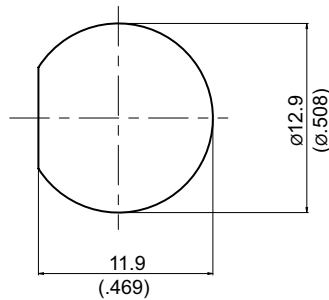

NOTE: IP67 compliant (waterproof) when mated.

Parts	Material	Plating (Micro-inch)
Gasket	Silicon	
Ferrule	Brass	Tin-Zinc-Copper-Alloy 100 Over Copper 50
Small Pin	Brass	Gold 4 Over Nickel Phosphorus Alloy 80 Over Copper 20
Hex Nut	Brass	Tin-Zinc-Copper-Alloy 100 Over Copper 50
Washer	Brass	Tin-Zinc-Copper-Alloy 100 Over Copper 50
Barrel	Brass	Tin-Zinc-Copper-Alloy 100 Over Copper 50
Insulator	Teflon	
Contact Pin	Phosphor Bronze	Gold 4 Over Nickel Phosphorus Alloy 80 Over Copper 20
Body	Brass	Tin-Zinc-Copper-Alloy 100 Over Copper 50

Weight:
Suitable Cables:RG179

This part number complies with RoHS.

Notice: JYEBAO reserves the right to make modifications deemed appropriate.

CABLE ASSEMBLY INSTRUCTION

TNC8105WP-0179

JYE BAO CO., LTD.

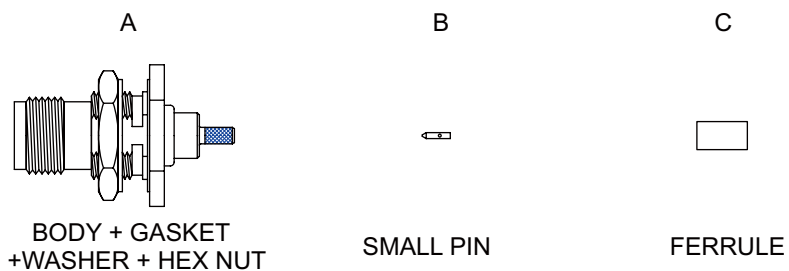
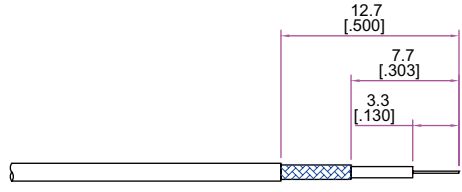
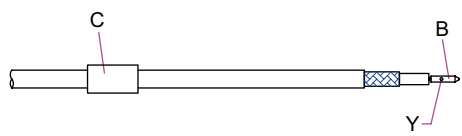
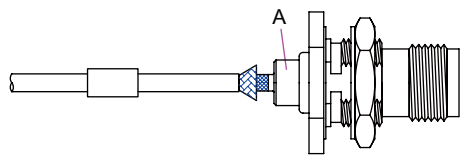
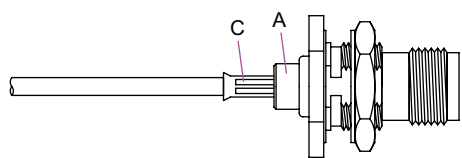

DIAGRAM	ASSEMBLY INSTRUCTION
	<p>Step 1: STRIP AS SHOWN .</p>
	<p>Step 2: SLIDE FERRULE " C " OVER CABLE. Step 3: PUT PIN " B " ON CENTER CONDUCTOR AND SOLDER IN " Y " .</p>
	<p>Step 4: LOOSEN BRAIDING AND SLIDE CONNECTOR " A " IN PLACE.</p>
	<p>Step 5: SLIDE FERRULE " C " TOWARDS THE CONNECTOR " A " AND CRIMP.</p>

This part number complies with RoHS.

Notice: JYEBAO reserves the right to make modifications deemed appropriate.